

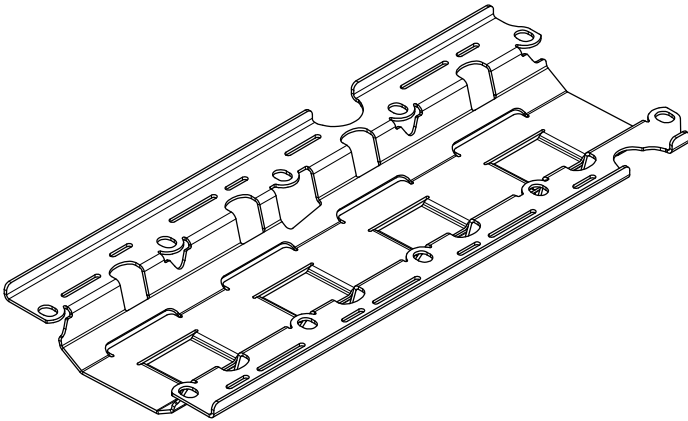

## PERFORMANCE ALUMINUM WINDAGE TRAY FOR GM LS / VORTEC ENGINES

PART NO. EGM-241

MADE IN USA



Important: Read these instructions in their  
entirety prior to installation.

For contact information, visit [www.improvedracing.com](http://www.improvedracing.com)  
Copyright © 2008-2022 Improved Racing Products, LLC. All rights reserved.

## APPLICATIONS

- 1997+ GM LS / Vortec engines with factory or aftermarket bottom ends, equipped with any of the oil pans shown in Table 1.
  - Fits LS / Vortec engines with up to a 4.000" stroke.
  - CAD-verified to fit the oil pans listed in Table 1 as well as the Holley 302-1 oil pan.
- This part may work with additional aftermarket oil pans if:
  - The aftermarket pan uses an oil pickup tube (screen) from a vehicle listed in Table 1.
  - The aftermarket pan uses dip stick hardware from a vehicle listed in Table 1.
  - The aftermarket oil screen fastens to the main cap locations shown in Figure 1.

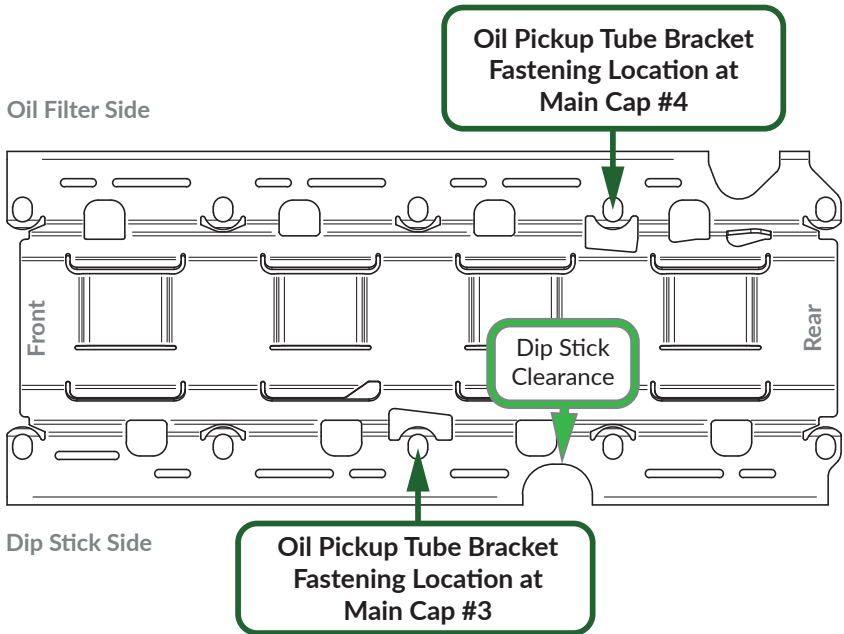

Figure 1 - Pickup Tube Fastening Locations for EGM-241

- See Figure 2 to verify the aftermarket pan is deep enough.
  - There should be at least 1.60" of clearance from the gasket surface.

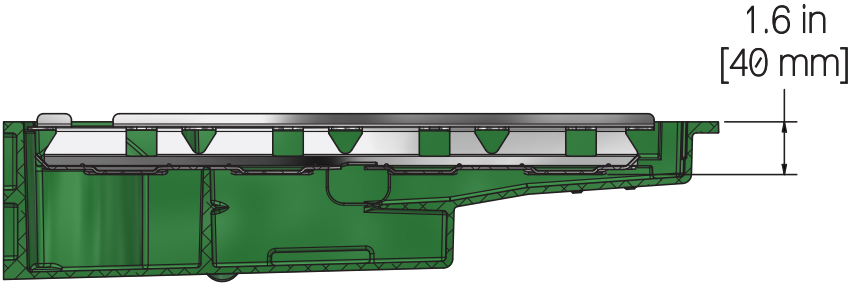

Figure 2 - Minimum Aftermarket Oil Pan Depth

- Expect to trim the tray for aftermarket oil pickup tubes.
  - Use a marker and cutting tool to trim the windage tray until it clears the oil pickup tube mounting bracket by about 1/8".

**⚠ DOES NOT fit 4.125" stroke engines.**

**⚠ DOES NOT fit LS engine blocks using stepped main caps, such as Dart Industry's LS Next engine blocks.**

- EGM-241 is verified to fit the following factory oil pans:

GM Part Number	Factory Oil Pan for These Vehicles
12599397, 12581209, 12599398 and 12581210	Holden Commodore (VT, VX, VY & VZ), 1997-2006 Holden Monaro (V2 CV8 & VZ), 2001-2005 Pontiac GTO, 2004-2006 Vauxhall Monaro, 2002-2005
12640748 and 12622559	Chevrolet Camaro SS (LS3 and L99), 2010-2015 Chevrolet Camaro ZL1, 2012-2015 Chevrolet Caprice (PPV) V8, 2006-2017 Chevrolet SS, 2014-2017 Holden VE/VF Commodore, 2006-2017 Pontiac G8 GT & GXP, 2008-2009 Vauxhall VXR8, 2008-2017

12640746, 12619776 and 12627903	<p>Cadillac Escalade, 2007-2014</p> <p>Chevrolet Avalanche, 2007-2013</p> <p>Chevrolet V8 Gasoline Express, 2008-2020</p> <p>Chevrolet V8 Gasoline Silverado, 2007-2015</p> <p>Chevrolet Suburban, 2007-2014</p> <p>Chevrolet Tahoe, 2007-2014</p> <p>GMC V8 Gaoline Savana, 2008-2020</p> <p>GMC Yukon / Yukon XL, 2008-2013</p> <p>Hummer H2, 2008-2009</p>
12613437	<p>Buick Rainier (5.3L), 2004-2007</p> <p>Chevrolet SSR (5.3L, 6.0L), 2003-2006</p> <p>Chevrolet Trailblazer (5.3L, 6.0L), 2003-2009</p> <p>GMC Envoy (5.3L), 2005-2009</p> <p>Saab 9-7x (Arc / 5.3i, Aero), 2005-2009</p>

**Table 1 - EGM-241 Verified Fit Factory Oil Pans**

## **PARTS LIST & HARDWARE**

<b>Qty</b>	<b>Part Number</b>	<b>Description</b>
1	EGM-241	Windage Tray
9	HSP-1009	Reducer Bushing for Factory Main Studs
10	HNT-1018	M8 Lock Nut for Factory Main Studs

## **TECHNICAL SPECIFICATIONS**

<b>Maximum Operating Temperature</b>	302°F (150°C)
<b>Minimum Operating Temperature</b>	-22°F (-30°C)
<b>Dimensions</b>	Refer to Figure 3
<b>Weight</b>	18.1 oz (514 g)
<b>Tray Material</b>	5052-H32 Aluminum Sheet
<b>Bushing Material</b>	6061-T6 Billet Aluminum

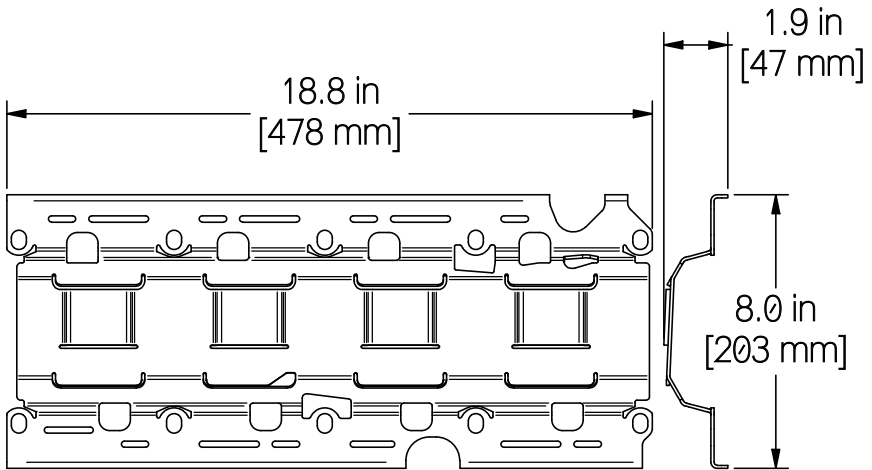







Figure 3 - EGM-241 Dimensions

## BEFORE YOU BEGIN

-  **WARNING: NEVER work under a vehicle supported by only a jack.**
-  **WARNING: This product should only be installed by a qualified mechanic. Improper installation could result in severe engine damage.**
-  Replace the oil pump O-ring and oil pan gasket during installation.
-  Consider installing an oil pump flange brace, such as EGM-500.

## INSTALLATION INSTRUCTIONS

1. Review the vehicle's service manual and follow the steps to remove the oil pan and windage tray.
  2. Clean the windage tray to remove any contaminants left from the manufacturing process.
  3. Install the new windage tray:
    - a. If using factory sized main studs, install the included HSP-1009 adapters over the windage tray (on the oil pan side) to help center the tray on the stud. The kit may include more adapters than required for your application.
-  **IMPORTANT: DO NOT install the HSP-1009 adapters under any oil pick up tube mounting bracket locations. This will cause the oil pickup**

tube to be spaced down lower than it should.

- b. If using aftermarket main studs, proceed without installing the HSP-1009 adapters.

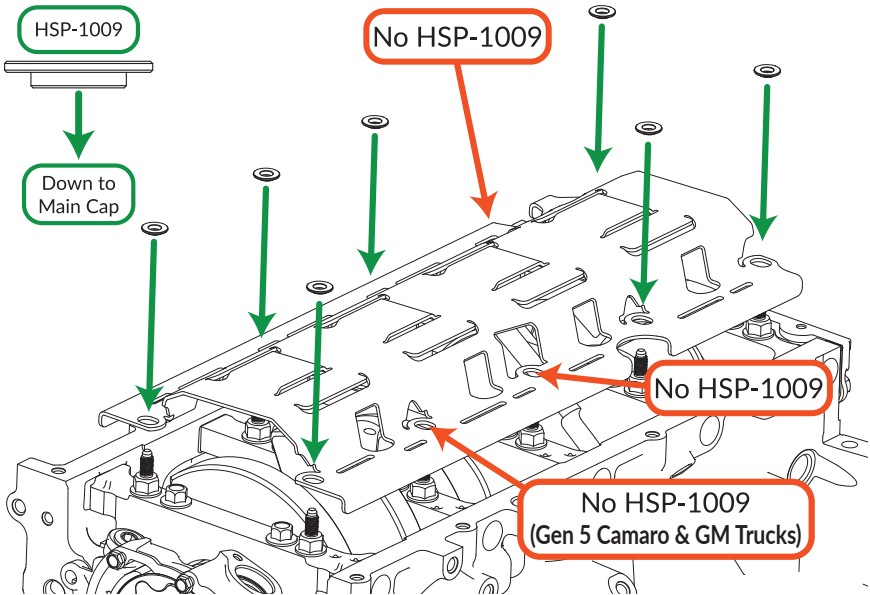

Figure 4 - Install HSP-1009 Adapters on Factory Main studs

4. Secure the new windage tray:
  - a. For factory main studs, use the included M8 lock nuts.
  - b. For aftermarket studs, use the nuts supplied with the stud kit.
- ⚠ Turn the engine clockwise using a 24mm (15/16") socket and breaker bar on the crank pulley to confirm there is no interference between the new windage tray and rotating assembly. Loosen and adjust the new tray until clearance is confirmed.
5. Perform the remaining steps in the vehicle's service manual to reinstall the oil pickup tube and oil pan.
- ⚠ **IMPORTANT:** Ensure the oil pickup tube flanges are flush with the oil pump and the new windage tray.
- 🚩 Installation is now complete. Thank you for purchasing an Improved Racing product!