

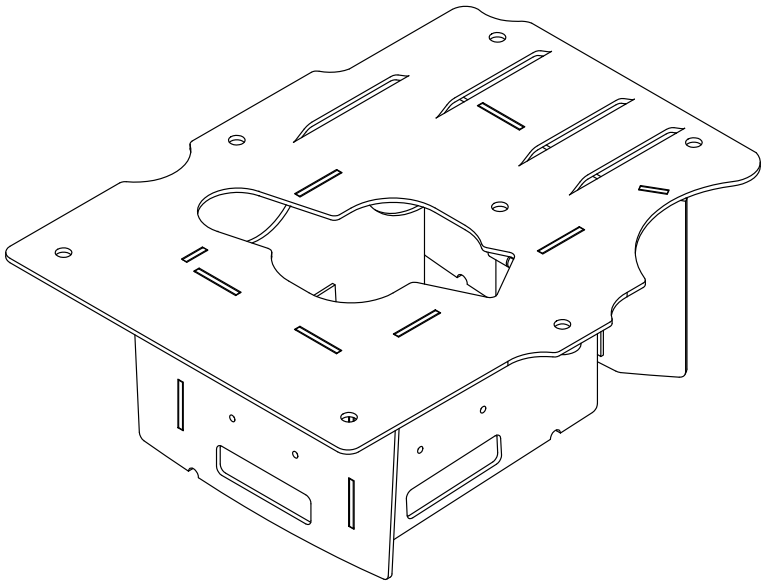

## CADILLAC CTS-V OIL PAN BAFFLE

**PART NO. EGM-206**

Made in USA



**Important: Read these instructions in their entirety prior to installation.**

For contact information, visit [www.improvedracing.com](http://www.improvedracing.com)  
Copyright © 2008-2020 Improved Racing Products, LLC. All rights reserved.

## APPLICATIONS

This product is designed for direct installation into the factory oil pans of the following vehicles:

- 2004-2007 Cadillac CTS-V (LS2 and LS6)
- 2008-2015 Cadillac CTS-V (LSA)
- Other vehicles equipped with the 2004-2015 Cadillac CTS-V oil pan
  - Current GM Part Number: 12631828

## INSTALLATION INSTRUCTIONS

**⚠️ This product should only be installed by a qualified mechanic. Improper installation could result in severe engine damage.**

1. Clean EGM-206 with a degreaser or detergent to remove any harmful contaminants. Rinse and dry.

**⚠️ Failure to properly clean the baffle can lead to oil contamination and engine damage.**

**💡** Shake the baffle to ensure all of the trap doors open and close freely

**💡** Contact Improved Racing for support if the hinges stick.

2. Drain the engine oil and remove the oil filter.
3. Refer to the instructions in the vehicle's factory service manual to remove the oil pan from the vehicle completely.
4. Use a 10 mm tool to remove the factory oil pan baffle from the oil pan.

**💡** Save the screws as they will be reused.

**💡** When required, clean the oil pan to remove oil residue and sludge buildup.

5. Use a 1-1/8 inch tool to remove the oil level sensor shown in Figure 1 below.

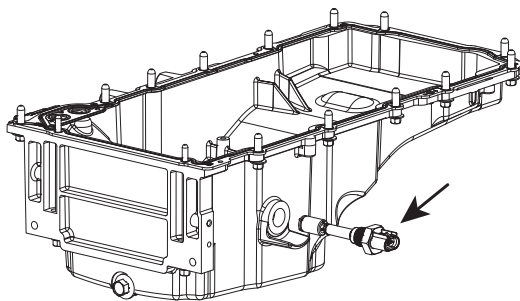

**Figure 1 - Removing the Oil Level Sensor**

6. Remove the spacers from their bag and ensure that there are five spacers.
7. Thinly-apply grease onto the face of each spacer as shown in Figure 2.

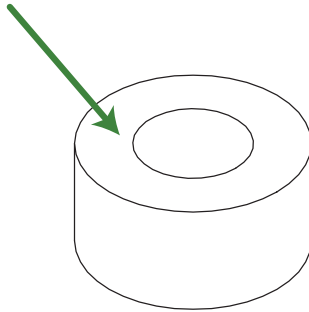

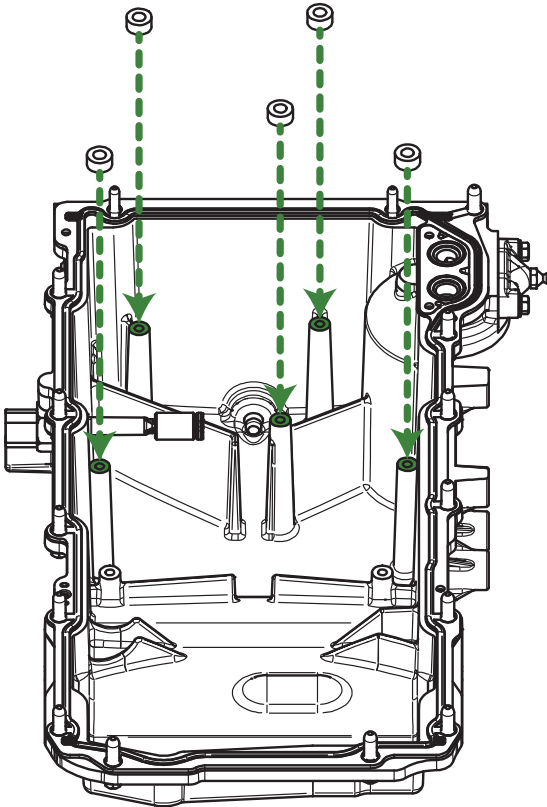

**Figure 2 - Applying Grease to Spacers**

8. Place each greased spacer onto the oil pan bungs as shown in Figure 3.
-  The greased side faces the oil pan bungs so they stay put during install.



**Figure 3 - Placing Spacers onto Oil Pan Bungs**

9. Place EGM-206 into the oil pan and onto the spacers, carefully so that they do not get knocked off.
  10. Carefully insert all seven screws saved from Step 4 into EGM-206 and hand-start the screws into the oil pan.
  11. Use a 10 mm tool to permanently secure EGM-206 to the oil pan. Torque the screws to 106 in-lbs (8-9 ft-lbs).
  12. Reinstall the oil level sensor into the side of the oil pan. Torque the sensor to the GM specification.
-  Replace the oil pan gasket and pickup tube O-ring with new components. This step is recommended for higher mileage engines.
13. Refer to the instructions in the vehicle's factory service manual to reinstall the oil pan.
-  **Oil pan alignment is crucial.**
14. Replace the oil filter, tighten the drain plug and refill the engine with oil to the GM factory specifications.

## CONCLUSION

Your vehicle can now benefit from improved oil control. Be sure to review the sections that follow for the best performance when using EGM-206.

## USE AND PRECAUTIONS – IMPORTANT!

- This product is designed to provide superior protection against oil starvation and slosh over the factory oil pan baffle.
- The sources of oil starvation are varied and this product will not protect your engine from damage in all circumstances.

 **Never let the oil level drop below the “full” mark at the race track.**

## PLEASE FOLLOW THESE RECOMMENDATIONS:

- Install an oil pressure gauge with a low-pressure alarm the driver can hear or see.
-  Pressure gauges are critical for preventing catastrophic engine damage and will help determine the limits of your setup.
- We recommend overfilling the sump by  $\frac{1}{2}$  quart prior to track events.
  - Always inspect oil levels between track sessions.

 **Never let the oil level drop below the “full” mark.**

- If oil pressure drops still occur, consider adding an oil accumulator and overfilling the sump by up to 1 quart.
- Vehicles that sustain over 1.4 lateral G's (significant aerodynamic assists and/or racing compound tires) and vehicles with high shift points should use a dry sump oiling system.

## **EXHAUST SMOKE:**

- When racing with an overfilled sump, it is common to see white or bluish smoke exiting the exhaust system.
- This is caused by excess oil entering the intake through the PCV system.
- We recommend installing an oil catch can on the PCV line to prevent this from happening.

## **DRAINING THE OIL:**

- Run the engine for ten minutes before draining the oil.
-  This will warm the oil and make it thinner for quicker draining.
- Draining the oil with the baffle installed will still take longer than usual.
  - Allow the sump to drain for at least ten minutes to ensure all of the oil has been removed.