

# F-Body Trap-Door Road Race Baffle



## Applications

This product is designed for direct installation in the following vehicles:

- 1998-2003 Pontiac Firebird equipped with LS1 5.7-liter V8 engine and stock GM oil pan
- 1998-2003 Chevrolet Camaro equipped with LS1 5.7-liter V8 engine and stock GM oil pan
- Hot-rod vehicles and kit-cars equipped with an LS-series engine that utilizes the stock GM oil pan from the vehicles mentioned above (GM part #12598151)

## Installation Instructions

**Warning: This product should be installed by an expert mechanic.**

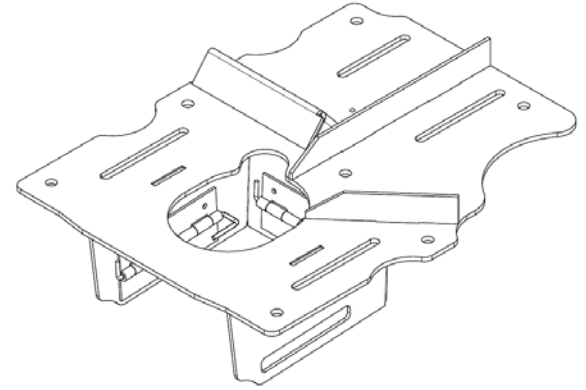

1. Your new baffle will have aluminum particles and residue on it from fabrication. Before installation, wash your new baffle with water and dish soap. Rinse and dry thoroughly with a lint-free towel.
2. Follow the instructions in your vehicle's factory service manual to remove your oil pan.
3. Unbolt the stock oil pan baffle by removing the 7 bolts that secure it to the pan. You will re-use these bolts.
4. At this point, you may want to clean your oil pan to remove oil residue and buildup.
5. Position your new baffle inside the pan. Make sure all of the bolt-holes line up properly.
6. Secure your new baffle to the pan with the 7 bolts you removed earlier.
7. At this point, you may want to replace your oil pan gasket and pickup tube o-ring. This step is optional, but recommended.
8. Follow the instructions in your vehicle's factory service manual to reinstall your oil pan.
9. Refill your engine with oil to the factory-recommended level.
10. Congratulations! You can now benefit from improved oil control. Be sure to follow the recommendations listed below when tracking your vehicle. Remember: **never** let the oil level drop below the "full" mark while tracking your vehicle!

## Use and Precautions – Important!

This product is designed to provide superior protection against oil starvation and slosh over the stock oil pan baffle. The sources of oil starvation can be varied and this product will not protect your engine from damage in all circumstances.

### Please follow these recommendations when using this product:

- When tracking your vehicle, always top off oil levels between sessions. Do not allow the level to drop below the full mark.
- If you have a 1998 engine block: Keep pan overfilled by at least 1 quart of oil when tracking your vehicle.
- If you rev your engine 200-600 RPM higher than stock: Keep pan overfilled by at least ½ quart.
- If you rev your engine more than 600 RPM higher than stock: We highly recommend installing an oil accumulator in addition to the F-Body Trap-Door Road Race Baffle.
- If your vehicle is a highly modified, dedicated race car or regularly pulls more than 1.3 sustained G's on turns: At the very minimum, install an oil accumulator in addition to the F-Body Trap-Door Road Race Baffle and overfill by 1 quart. A dry sump system should be strongly considered.

**You, the purchaser, are responsible for taking the necessary precautions to avoid damage to your engine or vehicle caused by oil starvation. Improved Racing, its owners and affiliates are not liable for any damages or losses of any kind incurred while using the F-Body Trap-Door Road Race Baffle.**

## Warranty

Our baffles are covered by a 1-year warranty. If your baffle is defective or fails under normal use, you may return it for a replacement baffle. Baffles that are damaged while not installed and baffles that are abused or otherwise used in any way other than what was intended by the manufacturer are not eligible. All warranty claims must be approved before the baffle is returned. If you would like to submit a claim, please visit our contact page on our website at <http://www.improvedracing.com>. Baffle must be shipped at customer's expense. Modified baffles are not exchangeable.

## Returns

We offer a 30-day money back guarantee. If you are unsatisfied with your baffle for any reason, you may return it within 30 days of purchase for a full refund. All returns must be pre-approved. If you would like to request a return, please do so via our contact page on our website at <http://www.improvedracing.com>. Shipping costs are non-refundable. Returned baffles must be shipped at customer's expense. Modified baffles are not returnable.

## Legal Notice and Terms of Sale

- The term "this product", as used throughout this document, refers to the F-Body trap-door road race oil pan baffle offered by Improved Racing.
- This product is intended for off-road use only and does not necessarily meet required federal regulations for road-going vehicles.
- Although extensive research and development was conducted and testing showed a significant improvement in oil control, several factors can affect performance and individual experiences may vary.
- While care was taken in the design and development of this product, racing is a dangerous activity and the purchaser assumes all risk and liability associated with the use of this product. These risks include but are not limited to damage, loss, injury or death.
- Improved Racing and its owner(s) are not liable for any losses or damages of any kind incurred while using this product.
- By purchasing this product, the purchaser agrees to the terms of this agreement.